

## Selectable 2 or 3 Dimensional Current Meter

*Compact, cost-effective, high-accuracy meters with vector-averaged current speed and direction*

### **Enhanced Design, Specifications, Performance**

The Falmouth Scientific, Inc. enhanced Acoustic Current Meter delivers extremely precise 2 or 3 dimensional velocity measurements (user selectable) in a defined free field. The **ACM-PLUS** uses the most accurate and stable current measurement techniques available today and is configured with standard features that are options on competitive instruments such as **extended on-board data memory, fast download capability, high accuracy real-time clock, and high speed data sampling.**

The instrument incorporates an internal compass and tilt sensors to provide true current vector direction. The unit's compact size and light weight make the **ACM-PLUS** well suited for multiple meter arrays. Windows-based software for meter setup, data collection and data visualization make the FSI **ACM-PLUS** very user-friendly.

The **ACM-PLUS** is available in either shallow-water or deep-water housings. The device may also be equipped with an optional pressure sensor, an optional CTD module, and can be configured to log up to two analog inputs from external sensors (e.g., DO, OBS, etc.).

### **FEATURES**

- Compact, lightweight, low-maintenance construction
- **User Selectable 2 or 3 axis** true cosine response velocity measurement
- Accurate velocity measurement with excellent low-velocity resolution
- Electronic magneto-resistive compass with 2-axis tilt sensor
- **Fast Data Sampling up to 10 Hz**
- Water Temperature measurement
- Extremely long battery life with low-maintenance alkaline batteries
- Real-time output/display capability; **Fast Data Download**
- Long-term data logging to **2 GigaByte internal flash memory**
- ASCII serial data output via RS-232 or RS-485 (set at factory)
- Built-in **High Accuracy** real-time clock with on/off power control
- 1.5-ton working strength mooring frame standard; options for 5-ton mooring frame or frame with mooring line clamps
- Optional pressure sensor or integrated conductivity, temperature, pressure sensor module (CTD) may be added
- **Choice of epoxy shallow-water (200m) or titanium deep-water (7000m) housings**



*ACM-PLUS-200 shown with Integrated CTD and 5 Ton Frame Options*

# SPECIFICATIONS

## Sensors

Parameter	Type	Range	Accuracy	Resolution
Velocity	Acoustic	0 to 600 cm/s	$\leq 1\% \pm 0.5$ cm/s	0.01 cm/s
Direction	3 Axis Magnetometer	0 to 360°	$\pm 2^\circ$	0.01°
Tilt	2 Axis Accelerometer	0 to 30°	0.5°	0.01°
Temperature	Semiconductor	-3 to 40°C	$\leq 0.1^\circ\text{C}$	$\leq 0.01^\circ$
Pressure (optional)	Strain gauge	0 to 200 dBar 0 to 7000 dBar	$\pm 0.1\%$ full scale	0.01% full scale

## Optional CTD

	Range	Accuracy	Resolution	Stability
Conductivity (mS/cm)	0 to 70	$\pm 0.01$	.001	$\pm 0.0005$ per month
Temperature (Celsius)	-5 to 32° ITS-90	$\pm 0.01^\circ$	.001°	$\pm 0.0005^\circ$ per month
Pressure (dBar)	0 to 200 dBar 0 to 7000 dBar	$\pm 0.1\%$ full scale	0.01% full scale	$\pm 0.01\%$ per month

## Instrument

<b>External Power:</b>	8 to 32 VDC
<b>Current Draw:</b>	15 mA at 1 Hz sample rate; 80 mA at 10 Hz sample rate; 150 uAmp sleep
<b>Battery Power:</b>	Alkaline 5 D Cell Welded Pack, 10 AHR
<b>Internal Memory:</b>	<b>2.0GB Standard</b>
<b>Sample Rate:</b>	<b>10 Hz Maximum</b>
<b>Vector Averaging Period:</b>	<b>User Selectable up to 59 Min:59 Sec</b>
<b>Real Time Clock:</b>	Programmable <b>High Accuracy</b> Sampling/Low-power Mode
<b>Sampling Modes:</b>	Continuous, Interval, and Delayed Start (continuous or interval)
<b>Clock Stability:</b>	+/- 2ppm (0-40 degrees C); +/-4ppm (-40 degrees C to +85 degrees C)
<b>Input Channels:</b>	Two (2) 0-5V DC Input Channels with 12 bit A/D resolution available for external sensor input, such as; Transmissometer, DO, OBS, etc. (Regulated 12 VDC 1.5W provided to power external sensors)
<b>Depth Rating/Physical Material:</b>	200 Meter Epoxy Housing Standard, P/N: ACM-PLUS-200 7000 Meter Titanium Housing Optional, P/N: ACM-PLUS-7000
<b>Mooring Frame:</b>	1.5 Ton 316 Stainless Steel Mooring Frame (Standard, shown below left) 5 Ton 316 Stainless Steel Mooring Frame (Optional; shown below right) 5 Ton 316 Stainless Steel with Mooring Line Clamps (Optional, not shown)

Specifications Subject to Change without Notice

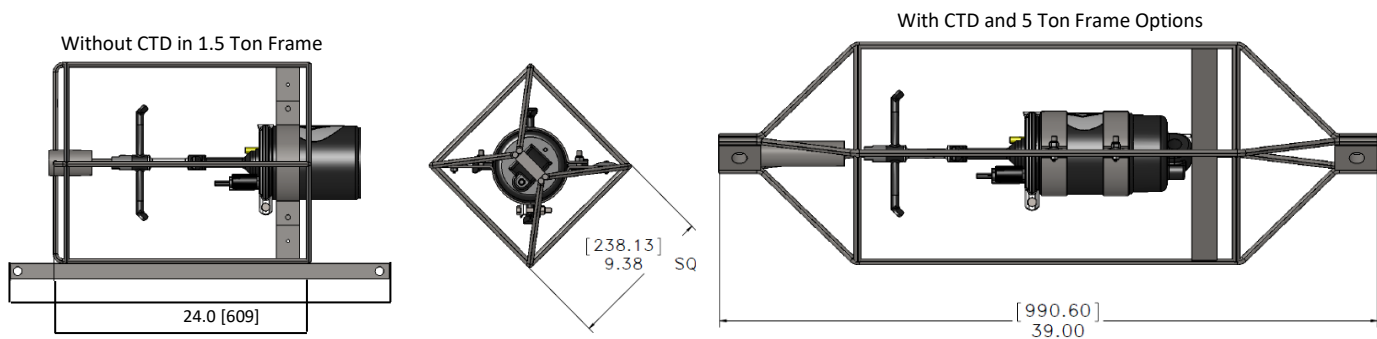

Outline Dimensions in inches [mm] are shown for the ACM-PLUS-200 with and without Optional Integrated CTD Module, and in standard 1.5 ton and Optional 5 ton Mooring Frames; contact FSI for ACM-PLUS-7000 info or further details.

30March2015

Falmouth Scientific, Inc.

33 Jonathan Bourne Dr, PO Box 326, Pocasset, MA 02559

[sales@falmouth.com](mailto:sales@falmouth.com) • Tel: 508-564-7640 • Fax: 508-564-7643 • [www.falmouth.com](http://www.falmouth.com)